

STUCCHI 1950 S.r.l.

Sede Legale:

Via Arcisate, 15
20157 Milano Italy

Sede Operativa:

Via M.te Bisbino, 24
20021 Baranzate (MI)

Tel +39 02/36538904

Fax +39 02/39292706

Site: www.stucchi.net

e-mail: info@stucchi.net

Document code:

**M00026AG
OPERATION AND MAINTENANCE MANUAL**

Machine model:

**Mobile bench exhauster
ST2-TF-EX Atex**

Serial no./Year:

**“TRANSLATION OF
ORIGINAL INSTRUCTION”**



*The manual is also
available through the
following QRcode*



This manual must be considered an integral part of the machine and must always be available to any persons interacting with the machine; the manual must always accompany the machine in the event of transfer or sale to another user.

This document is the property of the Manufacturer and/or representative and may not be reproduced or transferred to third parties without authorisation in writing.

The client is obliged to observe industrial confidentiality, and therefore the following documentation and relative attachments must never be tampered with or modified, reproduced or transferred to third parties, without prior authorisation from the manufacturer.

All operators must read this manual with care and strictly observe all instructions provided. The manufacturer shall not be held liable for damage to objects/the machine and/or physical injury in the event of failure to observe the specifications given below.



1 - Introduction

TERMS OF GUARANTEE AND SUPPLY

The Manufacturer is the entity that produces the machine, author and proprietor of of design; the term "manufacturer" may also be used to refer to a delegated agent, hereinafter referred to simply as Manufacturer;

The Client is intended as the final user of the technical asset or product;

The product is intended as the machine, quasi-machine, equipment or technical asset, governed in Europe by the directive 2006/42/CE.



The manufacturer hereby declares that the machine complies with the provisions of current legislation in EU member states and issues the enclosed DECLARATION OF CONFORMITY.

The Manufacturer is liable exclusively for defects arising from normal use of the machine. This excludes parts subject to normal wear, or in the event of damage or deterioration caused by improper use of the machine.

THE PERIOD OF WARRANTY is 12 months (D.Lgs. 2 febbraio 2002, n. 24)

Stucchi s.r.l. guarantees another 12 months warranty (Excluding defects in commercial components)

The sleeve filters are guaranteed for 5 years

The machine and mechanical parts deemed defective at source are covered by warranty. During the period of warranty, all part disassembly or replacement operation must be performed in the presence of the manufacturer's specialised technical personnel; failure to observe this requirements will render the warranty null and void.

No other warranty applies to damage caused by freezing, high temperatures and failure to observe instructions related to maintenance.

For commercial elements of the machine (electric motors, reduction gears, bearings, cylinders, solenoid valves, etc.) the warranty is only acknowledged when these elements, after inspection of the material deemed defective, are effectively confirmed as defective at source (manufacturing defect).

The warranty does not cover machine downtimes, material waste, production failures etc.

Any complaints must be made in writing to the Manufacturer within 8 (eight) days from the date of receipt, enclosing a copy of the delivery documents.

ITEMS NOT INCLUDED IN SUPPLY

The Manufacturer shall not be held liable for defects or malfunctions deriving from: improper use of the machine; alterations due to transport or particular environmental conditions; failure to perform or improper maintenance; tampering or makeshift repairs.

The Manufacturer declines all liability for failure to observe all standards to ensure correct installation or any equipment installed upline or downline from the machine. It is not possible to envisage the diverse types of installation and environments where the machine is positioned, and therefore the Client must check the following on site:



lighting systems; foundations; safety clearances, noise emissions during processing; any requirements for explosion proof equipment, personnel clothing.

The Manufacturer shall NOT be liable for damage to objects and/or physical injury, or damage to the machine following use other than as specified in the documentation or in the event that the machine safety devices are not used (disabled) or are tampered with.

The Manufacturer declines all liability for damage of any type deriving from inappropriate or careless operations performed by unskilled persons or experts who perform operations on the machine that do not comply with the contents of this manual and attached documentation.

The Client is required to use exclusively original spare parts, installed as envisaged for their application.

The responsibility in relation to commercial components lies with the respective manufacturers. The manufacturer shall not be liable for processed materials or any hazards caused by the latter to personnel or the environment.



The Manufacturer is NOT liable for the disposal of products required to use the machine, maintenance or production: dust, spent lubricants, batteries, etc. and therefore the client must personally arrange for disposal of these substances, deemed potentially harmful to the environment, in accordance with current standards in the country of installation.

SUMMARY AND INDICES

1 - Introduction 2

TERMS OF GUARANTEE AND SUPPLY 2

ITEMS NOT INCLUDED IN SUPPLY 3

SUMMARY AND INDICES 4

 Analytical index..... 6

DOCUMENTS AND INTENDED USERS 8

 Requests for assistance 8

 Aim and structure of the document..... 9

 Personnel specifications..... 10

REFERENCE STANDARDS 11

SYMBOLS AND SIGNS..... 12

FIELD OF APPLICATION..... 13

 Use normally permitted..... 13

 Limits of application 13

 Unauthorized use 13

2 - Specifications..... 14

GENERAL CONDITIONS..... 14

TECHNICAL SPECIFICATIONS..... 15

MACHINE IDENTIFICATION 16

 CE marking..... 16

 CE declaration of conformity 17

MACHINE DESCRIPTION 18

3 - Protections and safety devices..... 19

GENERAL CONDITIONS..... 19

RISK ZONES AND OPERATIONS 20

 Installation conditions and environmental risks 20

 Thermal hazard 20

 Maintenance interventions and safety devices..... 21

 Disconnection from power sources 21

 Machine in movement or off 22

 Work environment lighting 22

 Noise levels 22

RESIDUAL RISKS 23

 Table: residual risks 23

4 - Lifting and Transport	26
GENERAL CONDITIONS	26
Lifting	26
Transport	27
Unpacking and cleaning of components	27
SPECIFIC UNIT LIFTING	28
Table: weights and lifting points	28
5 - Installation	29
GENERAL CONDITIONS	29
Installation procedure	29
Preliminary checks	29
Electrical system	30
Pneumatic system	30
6 - Instrumentation	31
GENERAL CONDITIONS	31
CONTROL PANEL	32
7 - Operation	33
GENERAL TERMS AND CONDITIONS	33
Start-up	33
Shutdown procedure	33
ELECTRIC CIRCUIT BOARD PROGRAMMING	34
Changing bag filter cleaning times	34
Changing the electric circuit board sensitivity	34
OPERATING MODES	35
8 - Maintenance	36
ORDINARY MAINTENANCE	36
ROUTINE MAINTENANCE	39
STORAGE AND SCRAPPING	40
Machine storage and prolonged disuse	40
Machine decommissioning, scrapping or disposal	40
Table: product disposal	40
9 - Attachments	41
GENERAL CONDITIONS	41
WAIVER	41
SPARE PARTS REQUESTS	42

Analytical index**B**

bag filters 32, 34

C

circuit board 18

cleaning 36

clothing 3, 13

compressed air filter 18, 24, 32, 33

compressed air inlet 35

condensate discharge device 37

condensate drainage 30

control panel 18, 32, 34, 35, 36

D

data plates 16

declaration of conformity 17

direct air 35

direct air line 18

discharge outlet 18

disposal 3, 20, 27

document 8, 9

dust collecting tank 18, 24, 25, 35, 38

E

EARTH connection 30

electrical cabinet 12

electrical outlet 18, 35

electrical panel 38

electric circuit board 35

electric panel 35

explosion 3, 12, 20

F

filter cleaning piston 18, 35, 38

fire 20, 29

G

guards 11, 12, 13, 21, 22, 23, 24, 25, 40

H

high temperature parts 12

L	
lighting	22, 29
lubricated compressed air filter.....	37
M	
mains switch.....	31
main switch.....	12, 18, 20, 21, 25, 30, 33, 34
N	
noise	22, 24
O	
operator	8, 12, 13, 15, 19
P	
personal protective equipment	21, 23
pneumatic tools	18
position specified	22
protection devices.....	12, 13
Q	
qualified professional personnel.....	8, 10, 12, 20, 21, 26, 29, 40, 41
R	
residual risks.....	23
S	
safety clearances.....	20, 29
safety valve.....	18, 35, 38
silencer	30
sleeve filters.....	2, 18, 24, 35, 38
slipping	12, 22
suction inlet.....	18, 35
suction mouth	37, 38
suction turbine	15, 18, 30, 32, 33, 35, 38
T	
Table: product disposal.....	40
Table: residual risks.....	23
Table: weights and lifting points.....	28
tools.....	18, 23, 24, 25, 35
W	
wheels	18, 35, 38

DOCUMENTS AND INTENDED USERS

This document is aimed at qualified professional personnel with experience in working in conformity with the most common safety standards and the specific tasks required; it is presumed that all personnel have the basic knowledge for their assigned task.



All professional personnel interacting with the machine must read all contents of this manual; they must also be informed on any RESIDUAL RISKS associated with use of the machine and products processed.

The manual CANNOT be considered a replacement for any lack of cultural or intellectual knowledge of the professional personnel who interact with the machine.

Personnel assigned for operation, maintenance and/or other operations related to the machine must have specific experience in working with this type of machine or similar equipment, or have undergone specific professional training.



The Client is responsible for all damage caused or incurred by personnel authorised to use the machine.

Some general safety provisions provided in this manual may be deemed excessive or even impossible to implement in a number of rare situations (e.g. initial start-up, special maintenance, no-load tests, faults and malfunctions etc.).

In these cases the operator, tooler or maintenance engineer may proceed according to their specific needs, provided that:

- they are fully aware of the task in hand;
- they have the necessary skills and training;
- they do not perform operations intentionally at risk to themselves.

The number of copies of this manual is supplied as stated on the purchase contract. The manual must be conserved for the entire life cycle of the machine, also in the event of transfer to third parties.

The manufacturer declines all liability in the event of the partial or complete lack of documentation.



A copy of this manual and additional documentation (technical specifications folder) will be available from the Manufacturer for a period of 10 years.

Requests for assistance

To facilitate contacts with the Client Service Centre, the Purchaser should provide the following information, with reference to the CE data plate on board the machine and/or on the cover page of this manual:

- Machine serial number and year of manufacture;
- Type of machine or model;
- Identification or description of the problem.

Aim and structure of the document

This document (OPERATION AND MAINTENANCE MANUAL) has been drawn up to provide a valid guide and ensure safe work and completion of all operations required to guarantee efficient maintenance of the machine.

All personnel interacting with the machine must have read and fully understood all contents of this document.

The original version of this document was drawn up in ITALIAN; therefore in the event of inconsistencies or doubts, request the "ORIGINAL INSTRUCTIONS" or further clarifications from the manufacturer.

In order to ensure optimal conservation of the manual, the following is recommended: take care not to damage contents when using; never leave the manual unattended during use and return it immediately to its place of storage after consultation.

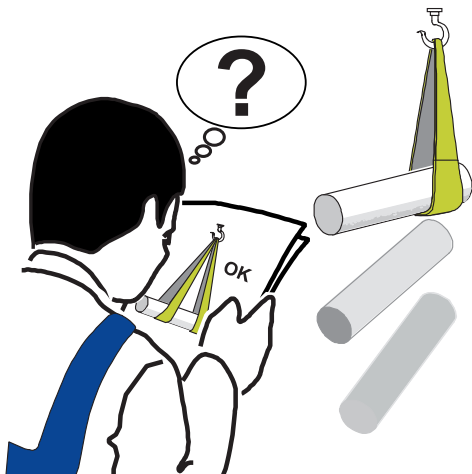

Never remove, tear or modify parts of this manual for any reason; any modifications or suggestions should be requested from the Manufacturer.

This manual is divided into CHAPTERS (INTRODUCTION, CHARACTERISTICS, ACCIDENT PREVENTION, etc.) as described in the CONTENTS.

The chapters and information are given in order of priority.

To improve efficiency and accessibility of the information in the manual, it is completed with an analytical index.



The information in this manual must never be considered replacements of safety provisions and technical specifications for installation and operation applied directly on the product, nor for rules based on common sense and current safety standards in the country of installation.

Personnel specifications

The personnel assigned to work on the machine must have attended specific professional training courses or possess adequate **experience gained on machines of this type**.

If NO training has been completed prior to installation and/or start-up of the system, the client is obliged to request this procedure and/or ensure that all conditions are met as envisaged in this document.

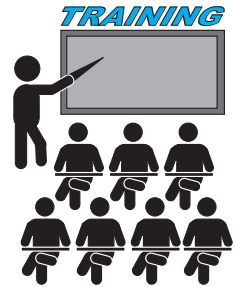

In order to avoid physical injury or material damage, we recommend that the client adequately informs all personnel regarding any RESIDUAL RISKS associated with use of this machine.

Personnel assigned for operation and maintenance of the machine must be sufficiently skilled, aware and mature for the tasks required and must be adequately reliable to correctly interpret all contents of this manual and to guarantee safety and rigorous checks as required.

The employment of UNQUALIFIED personnel, disabled or unskilled, under the effects of alcohol or drugs is strictly forbidden.

The Client is responsible for the skills and mental or physical condition of the qualified professional personnel assigned for machine operation and/or maintenance.

The Client or employer is civilly responsible for all damage caused or incurred by personnel authorised by the latter to use the machine.

The assigned personnel must meet the following requirements:

- complete ability to use the upper and lower limbs;
- ability to identify and recognise colours;
- good sight and hearing;
- ability to read and write;
- knowledge of danger and warning signs;
- ability to operate and control the work cycle, to verify correct operations and product quality, and to remedy or notify of faults when necessary;
- note down any relevant points or results to ensure the assigned quality, and optimal efficiency of the system.



Use of the machine by persons making use of sedatives, alcohol, drugs and/or psychotropic substances is strictly prohibited.



REFERENCE STANDARDS

This chapter indicates the International Standards and National Laws complied with in designing and constructing the machine.



- **2006/42/CE** New machinery directive for the CE mark (Abrogation of Directives 98/37/CE ex 89/392/CEE)
- **Directive 2014/34/EU** Equipment and protective systems intended for use in potentially explosive atmospheres.
- **UNI EN 1127-1:2011** Explosive atmospheres - Explosion prevention and protection - Part 1: Basic concepts and methodology
- **UNI CEI EN ISO 80079-36:2016** Explosive atmospheres Non-electrical equipment for explosive atmospheres - Part 1: Basic method and requirements
- **2014/35/UE** Low voltage directive.
- **2014/30/UE** Electromagnetic compatibility. D.Lgs. 18/5/2016.
- **2011/65/UE: 8-6-2011 (RoHS 2)** restriction of the use of certain hazardous substances in electrical and electronic equipment Text with EEA relevance.
- **Legislative Decree n° 81** of 9/4/2008 (june 2016) Implementation of the safety consolidation act (ex Legislative Decree 626/94 of 18/9/1994) directive for improving the health and safety of workers in the workplace.
- **UNI EN ISO 12100:2010** Safety of machinery - General principles for design - Risk assessment and risk reduction.
- **UNI EN 349: 2008** Machinery safety – Minimum distances to avoid crushing of parts of the body.
- **UNI EN ISO 14120: 2015** Machinery safety – General requirements for designing and constructing fixed and moving guards.
- **UNI EN ISO 4414: 2012** Machinery safety – Safety requirements for fluid power systems and their components – Pneumatics
- **IEC EN 60204-1: 2016** Machinery safety – Electrical equipping of machines Part 1: General rules.
- **UNI EN ISO 11202: 2010** Acoustics - Noise emitted by machines and equipment. Measuring noise pressure levels in the workplace and other specified positions – In-situ test method.
- **UNI 10893: 2000** Technical documentation on the product – Operating instructions.
- **UNI - ISO 10015: 2001** Guidelines for training.
- **ISO 7000 - DIN 30600** Graphic symbols and signs for identifying the functions.
- **UNI 11394: 2011** Technical information - Usability testing of instruction for use of technical goods



SYMBOLS AND SIGNS

<p>Obligation to consult document, which must be available for future use and never deteriorated in any way. Do not damage or delete document pages.</p>	
<p>Operations requiring special attention: General danger. Operations requiring compulsory use of authorised and qualified professional personnel.</p>	
<p>Hazardous voltage: normally affixed on the electrical cabinet protected by the main switch with automatic release mechanism. Obligation of system earthing.</p>	
<p>Zones subject to high temperatures: indicates the danger due to the presence of high temperature parts (risk of burns). Risk of explosion or the need to request specific explosion proof equipment.</p>	
<p> No smoking near the machine. It is forbidden to use naked flames near the machine. Presence of potentially flammable atmospheres and powders..</p>	
<p>Moving parts: risk of crushing hands or other parts of the body. slipping or falls: potential risks for the operator.</p>	
<p>General prohibition: indicates prohibited access to zone concerned or prohibited action or manoeuvre. Prohibited removal of protections on the machine. Never operate or perform maintenance on the machine with protection devices (guards) removed and/or open.</p>	
<p>Prohibition: On some models, be careful not to bump or damage pistons or protruding cables at the bottom of the machine center.</p>	
<p>Obligation: indicates the obligation to perform the described operations using the clothing and/or personal protective equipment provided by the employer (overalls, gloves, ear protectors, goggles, etc.).</p>	
<p>Obligation to dispose of electrical and electronic products in specific waste disposal centres and to arrange for classified waste separation to avoid environmental pollution.</p>	

FIELD OF APPLICATION

The Manufacturer declines all responsibilities due to damages of all kinds that may derive from incorrect or imprudent operations.

The machine **MUST NEVER** be used by unskilled personnel.



Use of the machine other than as specified in its field of application is strictly prohibited.

The machine has been designed and built for use in ATEX ZONE 22.

On the machine is affixed the following marking: CE Ex II 3D c T 50 ° C.



Use normally permitted

The machine dealt with in this manual has been designed to:

aspirate mixed air to powders produced by abrasive tools during machining of varnished or stuccoed surfaces; Filter the aspirated air by separating the heavy parts allowing it to be disposed of and returning to the filtered air environment.

Limits of application

The machine's field of application must remain within the limits as specified in the purchase contract and as described in the "Table: technical specifications", "and all contents of the manual.

Unauthorized use

The following is STRICTLY PROHIBITED:



- Use of the machine and any associated parts without having read and correctly understood the contents of the operation and maintenance manual.



- to heat or dry rags and clothing on high temperature parts This is not only dangerous but also prevents adequate ventilation and cooling of components.



- Use of all or part of the machine in environments subject to the risk of flammability. DO NOT induce or aspirate sparks due to working.



- Use machine parts by connecting it to other equipment and / or tools that do not meet the technical specifications.

- Use the machine with protection devices (guards) and safety not working or excluded.

- Use the machine without the clothing and / or personal protective equipment provided by the employer.



- For safety reasons, during processing, the presence of persons other than the operator is not permitted in the area surrounding the machine.

2 - Specifications

GENERAL CONDITIONS



The description of the machine characteristics enables identification of the main components of the machine and correct use of the technical terminology adopted in the manual.

The technical terminology is summarised in the chapter SUMMARIES AND INDICES.

The chapter SPECIFICATIONS contains information on the machine composition, the characteristics, dimensions and identification data.

Adjustment, operation and maintenance procedures are described below, on the presumption that the information in this chapter has been read and understood.

TECHNICAL SPECIFICATIONS

Your model is equipped as follows		ST2-TF-EX - EU	ST2-TF-EX - USA
	Power supply voltage	400 V ac +/- 5% - 50 / 60 Hz +/- 5%	208 V ac +/- 5% - 60 Hz +/- 5%
	Operator power supply voltage	12 Volt cc +/- 5%	
	Total electric power installed	2,2 kW +/- 5%	2,55 kW +/- 5%
Degree of protection		IP 66	
Matching tools			
Maximum power tools		1.000 W / cad	500 W / cad
Pneumatic tools			
Compressed air supply, dry and clean, in accordance with ISO8573-1:2010 Classe 1.4.2			
	Required pressure max (*)	9 bar / 126 Psi	
	Suction turbine engine	2,2 kW	2,55 kW
Suction volume (*)		306 m ³ /h	355 m ³ /h
Suction depression max (*)		220 mbar	175 mbar
Weight		60 kg	
Depth		50 mm	
Width		100 mm	
Height		132 mm	
	Maximum admissible no. of operators	2	
	(for n. tools)		
Admissible ambient temperature		da - 5 a + 35 ° C	
Admissible relative humidity		da 35 a 70 %	
Noise		<= 72 dBA	

(*) These values are valid at the normal atmospheric pressure of 1013 mbar

MACHINE IDENTIFICATION

CE marking



The data plates on board the machine must NEVER be removed, damaged, soiled, concealed etc.

If, due to an accident, the “CE mark” data plate is damaged, detached or other, the client must notify the manufacturer immediately.

The data plates should be cleaned periodically and kept visible at all times, i.e. NEVER hidden by objects or foreign parts (cloths, boxes, equipment etc.).

The technical data provided in this manual do not replace the information stated on the data plates affixed to the machine.

The position of the CE data plate is specified below.

<p>STUCCHI 1950 s.r.l. Via M.te Bisbino, 42 - 20021 Baranzate (MI) tel. +39 02/36538904 - Fax +39 02/33301084 www.stucchi.net - e-mail: info@stucchi.net</p>		<p>STUCCHI CE POWDERS EXHAUSTING SYSTEM</p>	
Model			
Matricola		Anno	
Tensione Volt / Hz		Potenza Watt	
Peso kg			

**Special
Marking**



CE declaration of conformity



The declaration of conformity is delivered separately; a facsimile of the declaration is provided below.



STUCCHI 1950 S.r.l.

Sede Legale: Via Arcisate, 15 - 20157 Milano
Sede Operativa: Via M.te Bisbino, 24 - 20021 Baranzate (MI)
Tel +39 02/36538904 - Fax +39 02/39292706
Site: www.stucchi.net - e-mail: info@stucchi.net



DICHIARAZIONE "CE" DI CONFORMITA' (Direttiva 2006/42, allegato II, lettera A)
DECLARATION OF CONFORMITY "CE" (Directives 2006/42, annex II, sheet A)

Il Costruttore: STUCCHI 1950 S.r.l.

The Manufacturer: **Sede Legale:** Via Arcisate, 15 - 20157 Milano
Sede Operativa: Via M.te Bisbino, 24 - 20021 Baranzate (MI) Italy

Responsabile Fascicolo Tecnico **Stucchi Sara**
Technical file Manager Via M.te Bisbino, 24
20021 Baranzate (MI) Italy

dichiara sotto la propria esclusiva responsabilità che la/e macchina/e nuova/e:
declares under its own responsibility that the new/s machine/s

Modello/model: XYZ
Matricola/Serial N.
ANNO di costruzione ??????????????

è/sono conforme/mi a tutte le disposizioni pertinenti della direttiva **2006/42/CE** ed alle seguenti direttive Europee:
conform/s to all relevant provisions of Directive 2006/42/CE and the following European directives:

2014/35/UE - 2014/30/UE - 2014/34/UE - 2011/65/UE

è/sono conforme/mi alle seguenti norme armonizzate:
conform/s to the following harmonized norms:

UNI EN ISO 12100: 2010 - UNI EN 1127-1:2011 - UNI CEI EN ISO 80079-36:2016
CEI EN 60204-1: 2006 - UNI EN 11202: 2010

ed inoltre è/sono costruita/e nel rispetto delle seguenti norme tecniche:
and moreover is/are built according to technical norms:

UNI 10893: 2000 - UNI ISO 10015: 2000 - UNI 11394: 2011

STUCCHI 1950 S.r.l.
Via M.te Bisbino, 24
20021 Baranzate (MI)

Data
Date

Responsabile legale **Stucchi Sara**

Legal Officer

firma
signature

LA PRESENTE DICHIARAZIONE DI CONFORMITÀ HA VALIDITÀ A DECORRERE DALLA DATA DELLA BOLLA DI CONSEGNA.
THE DECLARATION OF CONFORMITY HAS VALIDITY STARTING FROM THE DATE ON THE DELIVERY NOTE

MACHINE DESCRIPTION

The machine is composed of the following elements:

- a) pressure reducer and compressed air filter; the compressed air is connected to the filter;
- b) direct air line outlet; with line pressure;
- c) filtered air discharge outlet;
- d) filter cleaning piston;
- f) dust collecting tank;
- g) pneumatic valve;
- h) sleeve filters;
- i) connection compressed air for remote start suction turbine through pneumatic tools;
- o) main switch;
- p) control panel;
- q) magnetic flow valve and sensor; this allows the starting up of the machine when the operator uses the pneumatic tools;
- r) wheels;
- s) safety valve;
- t) suction turbine;
- u) electrical outlet for the remote operation of the suction turbine via the attachments (electrical tools);
- v) electric panel;
- w) circuit board;
- z) suction inlet for the connection of suction pipes.

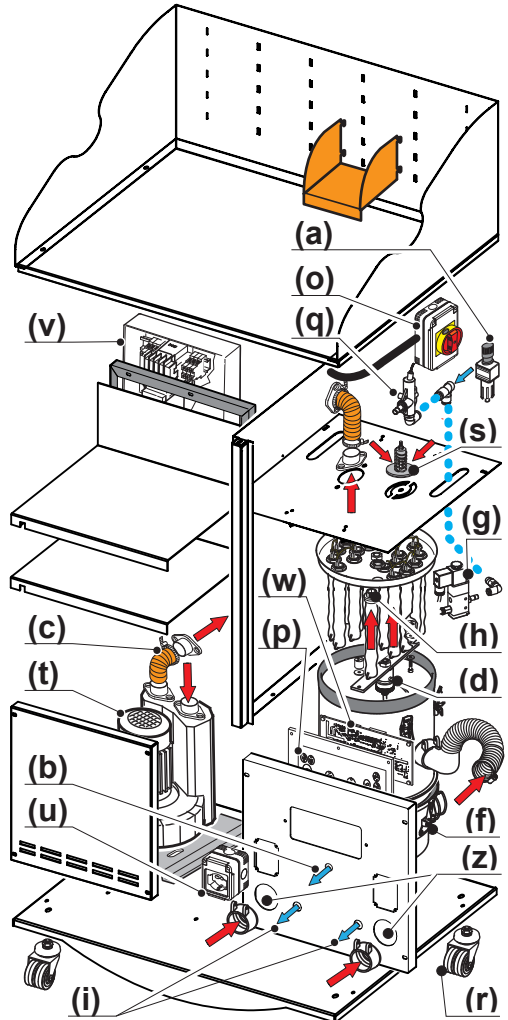

3 - Protections and safety devices

GENERAL CONDITIONS

The machine has been designed and constructed according to the most stringent accident prevention standards and equipped with safety devices to protect components and the operator.



For obvious reasons, it is not possible to envisage the diverse types of installation and environments where the machine is positioned, and therefore the Client must provide the manufacturer with adequate information on the specific installation conditions.

The information in this manual must never be considered replacements of safety provisions and technical specifications for installation and operation applied directly on the product, nor for rules based on common sense and current safety standards in the country of installation.



It is indispensable to provide operators with the correct information. Personnel must therefore read and observe all technical information provided in the manual and attached documentation.

Heavy parts or equipment (over 25 Kg) must be handled and/or lifted using suitable lifting equipment and via the relative lifting attachment points envisaged by the manufacturer.



Never use the machine if any type of malfunction is detected. Avoid makeshift repairs, and when making repairs ensure that exclusively original parts are used, which should be installed according to the envisaged use.



The responsibility in relation to commercial components lies with the respective manufacturers.

RISK ZONES AND OPERATIONS

Installation conditions and environmental risks

The machine cannot be installed outdoors or in adverse environmental conditions (sunlight, rain, wind etc.); also it is essential to observe the specified safety clearances to avoid hazardous situations.



The standard machine is not equipped to work in environments subject to specific risks of flammability or explosion; the explosion-proof configuration is only supplied on request.

Ensure that there is no electromagnetic interference.



Installation, removal and/or re-installation in a new site, as well as special maintenance operations must be performed exclusively by the manufacturer or qualified professional personnel with written authorisation from the manufacturer.



Before machine installation it is necessary to perform a classification of the installation area to verify that the ATEX category of the machine is the one required by the classified area.

The Manufacturer declines all liability for failure to observe all standards to ensure correct installation or any equipment installed upline or downline from the machine.

The machine has been designed in compliance with standards governing storage of energy and those related to energy savings.



The Manufacturer is not liable for the disposal of materials required to use the machine, maintenance or production: dust, spent lubricants, batteries, etc. and therefore the client must personally arrange for disposal of these substances, deemed potentially harmful to the environment, in accordance with current standards in the country of installation.

N.B. These conditions also apply for subsequent installations of the machine.

Thermal hazard



Due to overheating, the machine may have very hot surfaces (e.g. motors, coils, transformers, etc.) and therefore great care must be taken to avoid contact with these parts. In the event of a fire, use CO₂ type extinguishers to fight fires in closed environments.



Before using the fire fighting system, disconnect the machine from the power source by means of the main switch.

Maintenance interventions and safety devices

Protections or fixed guards can only be removed by means of specific tools; mobile guards, doors or gates can be opened but are protected by special safety systems.



The removal of protections or guards, or activation of the main switch with the door open is only admitted to qualified professional personnel and for special maintenance purposes only; on completion of the operation, the technician must restore all original conditions.



Removal of guards is only admitted 5 minutes after the power supply has been disconnected.



NEVER electrically bypass safety devices on the machine, to facilitate access or operating procedures.

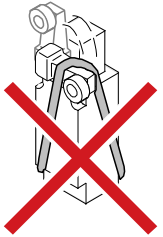

The main switch can be locked out with a padlock to avoid inadvertent operation; in any event ensure that no-one can reset or operate the machine in these conditions.

Maintenance personnel must notify the relevant persons of any fault or deterioration caused by wear or age.

The machine must be cleaned using compressed air or adequate means and detergents that do not attack any components; it is strictly prohibited to clean or wash the machine using pressure water jets.

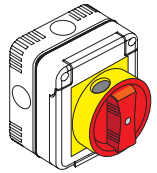

Personnel must NEVER access the machine or equipment with bare feet or wet hands.

In the case of metal surfaces, clean using a detergent solvent dilutable in water.



Personnel must wear the clothing and personal protective equipment provided by the employer.



Disconnection from power sources

To totally disconnect the machine from the electrical power mains, the main switch must be set to OFF.

It is necessary to disconnect the pneumatic part (if existing).

The compressed air supply pipe or turn off the compressor, as well as make sure there is no residual pressure in the system.

OFF

Machine in movement or off

The moving machine represents a potential hazard and therefore it is **STRICTLY PROHIBITED** to run it under no load conditions, perform maintenance or clean the machine while it is in operation. The operator must always take care in the surrounding work environment to ensure that there is a sufficiently large space to enable an escape route.

The operator must also maintain the position specified in the manual or by the employer.



Any foreign elements placed on moving parts and not part of the machine (e.g. wrenches, bolts, screwdrivers, etc.) must be removed before start-up of the machine.

Even when switched off, the machine can constitute a hazard: fixed or mobile guards, housings, terminals, sharp edges, etc. are inevitably exposed, so it is prudent to handle tools and work accessories.



Correct cleaning of the work environment can prevent accidents or superfluous risks. Even a small oil leakage can be hazardous, with the risk of slipping or falls.



Some models may have pneumatic devices that should not be operated improperly and in any case paying attention to possible crushing (eg piston shake filters or dust collecting dust collectors (if available)

Work environment lighting

The work station must be adequately lit to ensure safety of all work and maintenance operations. Lighting must be set up to avoid stroboscopic effects, glare, stress or shaded areas. If adequate lighting cannot be guaranteed, use of the machine is strictly prohibited.

Noise levels



The noise levels are those read in the work areas at a height of 1.6 metres , at a distance of 1 metre from the machine and a background noise of 70 dBA.

The noise emissions from the machine are normally below 80 dBA; if, for a variety of reasons and unforeseeable circumstances, the noise levels admissible by law are exceeded in the country of installation, the client is obliged to remove the causes or protect operators with adequate personal protective equipment (ear protectors), providing preventive information to sensitise all personnel regarding use of these devices, in addition to periodic hearing tests.

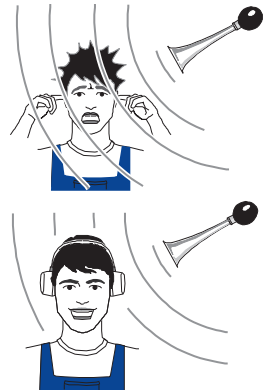

RESIDUAL RISKS



Despite the warnings and safety systems adopted by the manufacturer, some residual risks always remain, which are not possible to eliminate.



The residual risks are listed in the table below with a number of suggested preventive measures. The operator must read and observe all conditions stated below.

Definition of residual risk:





This is a non-evident risk, which cannot be reduced with the design of protection means and/or in any event cannot be eliminated and/or does not depend on the machine, but is due to actions performed by assigned personnel.





Due to the nature of the machine, failure to observe the safety instructions in this manual may lead to a number of hazards, even if all safety devices are installed correctly.

Table: residual risks

Description of risk	Danger zones	Suggested remedies
Crushing or injury for to inadequate manoeuvres during machine use, preparation or adjustments.	Opening closure of mobile and fixed guards.	Always use the personal protective equipment supplied by the employer and proceed with caution.
	Lifting or moving the machine without the means suitable for weight.	
	A Improper drive of pneumatic devices (es. Piston shake filters or lift dust collector pumps (if available).	
	Irresponsible or incorrect use of tools.	
Scalds or burns due to hot surfaces.	Hot tools during processing.	Allow components to cool down before accessing potentially temperature-sensitive parts. Always use the personal protective equipment.
	Improper access to the electrical system: Coils, motors, transformers, etc. ... can inevitably be overheated.	



<p>Slipping or falls due to distraction or lack of care in the work place.</p> 	<p>The area surrounding the work area is inevitably subject to dust.</p> <p>Check for leakage of oil from the lubricated compressed air filter (if present).</p>	<p>Keep the work environment, tools and equipment clean at all times, and proceed with caution in the work area.</p>
<p>Environmental pollution due to leaks or seepage or the type of material processed.</p> 	<p>In the vicinity of the machine; in particular where there is a pneumatic system, a dust collecting tank, a condensate discharge device, etc ...</p>	<p>Check the systems and clean the work environment thoroughly.</p> <p>Check the operation of suction systems and sleeve filters.</p> <p>Dispose of the products according to law..</p>
<p>Acoustic pollution due to type of processing or malfunction.</p> 	<p>Processing zone.</p> <p>Zone subject to high noise levels due to damaged or defective device.</p>	<p>Check compatibility tools.</p> <p>Check the source of noise emissions.</p> <p>Improve soundproofing, change work speed and wear suitable ear protectors.</p>
<p>Removal of protections and/or opening or removal or guards.</p> 	<p>Machine area where open shelters are present.</p> <p>Danger from dust inhalation.</p> <p>Area where security guards and / or micros have been temporarily removed.</p> <p>Opening of the guards, is only admissible 10 minutes after power has been disconnected.</p>	<p>Guards CANNOT be opened or removed while the machine is in operation, and any attempts to do this will disable maintenance.</p> <p>Do not use the machine with disconnected or defective protections guards.</p>

<p>Accumulation of energy, electrocution, electric shock (direct and/or indirect contact).</p> 	<p>Access to interior of electrical equipment for maintenance. Between terminals and live parts of electrical equipment.</p> <p>Pneumatic cylinders, solenoid valves, tools or devices.</p>	<p>Ensure that the main switch is set to "OFF" and locked out, (if possible). Make sure the line upstream of the main switch is disabled, then wait at least 10 minutes before accessing the machine, to ensure that all residual voltage is discharged from the power capacitors on the drives..</p>
<p>Improper or inadequate use of the machine and/or tools and device.</p> 	<p>Pneumatic system. Compressed air can cause serious injury if used to inflate objects or parts of the body.</p> <p>The presence of wheels (if present) can constitute a hazard on UNEVEN floors, also during transport.</p> <p>Inadequate cleaning; this can prevent reading of commands and safety data plates and constitutes a hygiene hazard.</p>	<p>Never use for purposes other than those envisaged in this manual.</p> <p>Take care and/or engage the parking brake when needed.</p> <p>Keep the work place, all signs on the machine and all instrumentation clean at all times.</p>
<p>Dangers of segregation.</p> 	<p>On some bulky models there is the potential risk of segregation inside the human or animal machine.</p>	<p>Always pay close attention when closing the guards. Make sure that they are not enclosed inside strange bodies.</p>
<p>Risk of fire.</p> 	<p>Machine, dust collecting tank and devices</p>	<p>Forbidden to smoke or use free flames near the machine is the dust collecting bin.</p>

4 - Lifting and Transport

GENERAL CONDITIONS

Lifting

Where indicated and/or envisaged in design, eye bolts are inserted and/or attachable for direct connection of hooks (if suitably formed) or shackles as shown in the figure.



Lifting operations must be performed exclusively by qualified professional personnel (slingers, crane operators, drivers, etc.)

The lifting means used (ropes, polyester straps, chains) must be suitable to withstand the load of the machine; the ropes must form an opening angle of less than or equal to 90°.

The lifting ropes must not damage the machine; if necessary protect it by inserting cloths or card.

During handling, ensure correct distribution of the load on the ropes and avoid any sudden or rapid movements that could cause hazardous swaying of the load.



Avoid the use of rollers for handling.

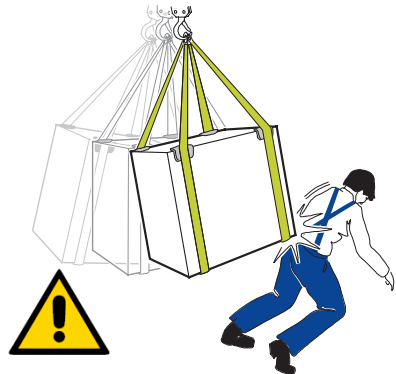
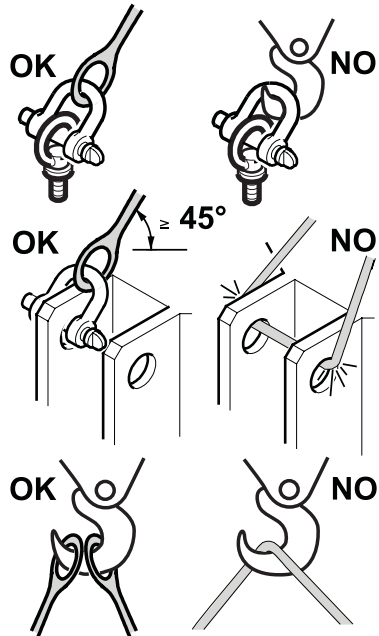

Transport

Transport of the machine, particularly on road, must be performed using means and procedures that ensure protection of the components (in particular electronics) against the risk of serious impact, humidity, vibrations etc.

Unpacking and cleaning of components



Always remember that packaging elements (wood, nails, cellophane, metal tacks, adhesive tape etc.) can constitute a hazard.

They should be removed by suitable means and never left in the hands of or accessible to irresponsible persons (e.g. children); the same applies to tools used for unpacking (scissors, hammers, pliers, etc.).



Packaging elements must be disposed of with care and the disposal must be in accordance with current standards in the country of installation.

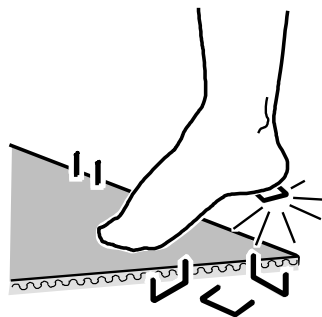

When opening the packaging, check that the machine is complete and intact and that there are no defects or signs of deterioration; if necessary suspend all procedures and contact the shipping agent, duly notifying the manufacturer of this fact.

Remove any protective film and proceed with thorough cleaning of the machine using suitable products according to the surface to be cleaned; avoid the use of benzene, trichloroethylene, solvents or abrasive products.



The handling area must be identified and inspected prior to all operations to check for the possible presence of danger zones.

In some cases, locking systems are intended exclusively for the transport of the machine; These components must be removed and stored for future handling or transport.

SPECIFIC UNIT LIFTING

Prepare the installation site before handling and positioning the machine.

The machine must be lifted in observance of the general conditions described above and using the attachments points envisaged in the manual, on the machine or packaging.

The following table summarises the weight (mass) and other data of the lifting equipment.



CAUTION:
*On wheeled units a braking systems **MUST** be envisaged, and the machine must never be left unattended.*



CAUTION:
The machine has been designed to be handled on a flat surface, and some units using a lift truck. In any event take great care at the fork insertion points and avoid the risk of the machine overturning.

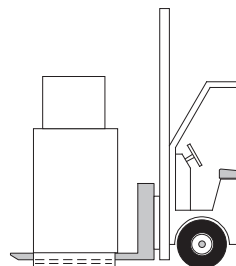

On some models, be careful not to bump or damage pistons or protruding cables at the bottom of the machine center..

Table: weights and lifting points

Description and dimensions for transport (Without packaging)	Mass weight in kg	Lifting points (Min. rope height)	Eye bolts UNI3266 Shackles UNI1947
Depth 50 mm	60	4 (2.000)	-
Width 100 mm			
Height 132 mm			

5 - Installation

GENERAL CONDITIONS

Installation procedure



This operation must be performed by qualified professional personnel and in strict observance of the specifications in this manual.

The operation and maintenance manual CANNOT replace a lack of technical knowledge of the installers. The installers must therefore be able to read and correctly interpret the diagrams attached or supplied previously by the client.

Preliminary checks

- Check to verify the envisaged ambient conditions (i.e. without explosive atmospheres or high levels of humidity) and that the machine is not exposed to adverse atmospheric agents such as rain, wind, etc.;
- Avoid electromagnetic interference, which may impair correct operation.
- Position the machine in an environment with safety clearances that enable routine work tasks/maintenance. Take care to position the machine where it does not create situations of discomfort or stress (windows or lighting that may create glare, draughts, confined spaces and obstacles etc.).
- Ensure that the machine is stable and level, and does not emit excessive vibrations.

- Check that there are no foreign bodies on the machine.
- The machine must be installed in areas requiring the presence of fire fighting equipment in accordance with current standards in the place of use.



The materials used do NOT normally constitute a fire hazard.

Electrical system

- Check that the specifications of the power mains correspond to those of the data plate and data in the *Table: technical specifications* in this manual.
- Make wiring for the electric line to main switch or the RST terminal board with cables and sheaths suited to the machine power (see *Table: technical specifications*); use an adequate cable, close the control panel and do not switch on until all the following operations have been completed and the operator is completely aware of all instruments and commands.
- Check the correct direction of rotation of the suction turbine by checking the air outlet from the silencer; If the silencer is sucked in reverse the phases.

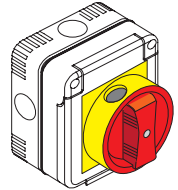

The power line must be fitted with a system for adequate protection against overloads or short circuits; protection against excessive voltage drops is also recommended. INSTALL a GENERAL thermal magnetic circuit breaker upline of the device supplied by the manufacturer on the machine.

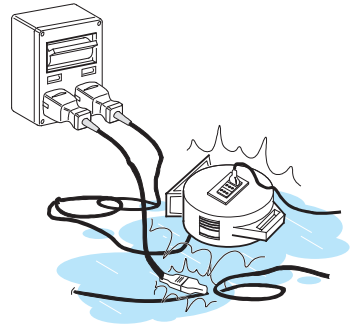

- All types of installation, check and/or maintenance operation must be performed exclusively with the power disconnector switch on, i.e. with the main switch off.



Make the EARTH connection to the relative terminal, connecting the cable to the nearest earthing point. N.B. The EARTH cable must have a section at least equal to that of the phase wires.

Pneumatic system

The pneumatic circuit is normally connected to the mains supply of the building.



The Customer must ensure that the system is protected against compressed air delivery exceeding 9 atm, and that air delivered is dry and NOT lubricated.

A compressed air filter is installed on board the machine with lubricator; The filter is connected to the compressed air.

The filter is equipped with dehumidifier with cartridge for the condensate drainage.



CAUTION: Compressed air may cause unexpected movements, and act with caution.

6 - Instrumentation

GENERAL CONDITIONS

It is essential to be completely familiar with the INSTRUMENTATION to avoid damage to the machine or harm to the operator.

Never use the machine if:



- *not adequately trained in use of this machine or similar machinery;*
- *not able to understand operation procedures;*
- *uncertain regarding the consequences of manoeuvres assigned;*
- *any faults or malfunctions are detected;*
- *there is any uncertainty or contradictory elements between personal experience, the manual and/or other operators.*

It is advisable to connect the machine to a mains switch or automatic power disconnect switch, possibly designed to be locked out with a padlock for maintenance purposes.

The employer must ensure that the personnel assigned to operate the machine have undergone suitable training.

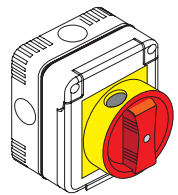







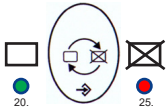

The manufacturer shall not be held liable for damage to the machine or harm to the operator when caused by incompetence, inadequate or lack of personnel training.

CONTROL PANEL

This model is equipped with an electric circuit board and a control panel for regulating and operating the suction system.

The buttons on the control panel have the following functions:

The numbers shown on the buttons indicate the times selected.

	<p>This button allows the inclusion or exclusion of automatic operation of electric or pneumatic tools. By switching the button to exclude, the tools can be used without suction.</p>
	<p>Button which allows extra cleaning of the bag filters, in addition to the normal programmed cleaning. This button allows manual operation of the filter cleaning piston.</p>
	<p>This button allows the manual operation of the suction turbine.</p>
	<p>Indicator light: when lit, it indicates that electrical tools are in operation at one of the system's points of use.</p>
	<p>Indicator light: when lit, it indicates that pneumatic tools are in operation at one of the system's points of use.</p>
	<p>Indicator light: when lit, it indicates that the suction turbine is running properly.</p>
	<p>Indicator light: when lit, it indicates that there is no oil left in the lubricated compressed air filter. The machine can still continue to operate: Ensure oil is replenished as soon as possible (OPTIONAL).</p>
	<p>Indicator light which indicates that the suction turbine has stopped due to overheating or an electrical anomaly.</p>

7 - Operation

GENERAL TERMS AND CONDITIONS

Before activating functions of the machine it is essential to be completely familiar with the INSTRUMENTATION and functions enabled by the commands, as well as the layout of all EMERGENCY buttons and STOP devices.



Before performing any type of operation, all personnel must have read, interpreted and correctly implemented all conditions specified previously in this manual and/or in the attachments.

The software program may not be converted and/or change the operation.

Start-up



When the machine is powered up, keep at a safe distance as inadvertent movements may occur.

- Plug the power supply from the customer line.
- Read and take into account all associated RESIDUAL RISKS.
- Check that there are no other persons in the work area.
- Power up the machine by means of the main switch.
- Make all necessary adjustments and proceed with operation.

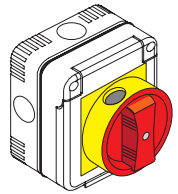

Shutdown procedure

- Press the STOP button for the suction turbine (if present);
- Turn the main switch to the OFF position;
- Unload the pneumatic system on the compressed air filter;

ELECTRIC CIRCUIT BOARD PROGRAMMING

On this model, the control panel allows to change the cleaning intervals for the bag filters and the electric sensitivity of the electric circuit board to optimise the automatic start-up of the power tools.

Changing bag filter cleaning times

- Switch off the control panel using the master switch.
 - Hold down the button shown at the side and simultaneously turn the machine back on using the master switch.
- Now by pressing this button multiple times you can select the desired interval for the filter cleaning, which will be shown by the relative indicator light lighting up; the indicator lights are positioned on the various buttons.

The time intervals are: 5' – 10' – 15' – 20' – 25'.

N.B. The default setting is 15'.

- Press the ENTER button shown at the side to set or confirm the desired interval.



In any case a quick cleaning of the filters is performed every 3 times the machine is restarted/switched on (a fixed interval cannot be set)

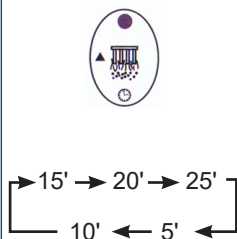

Changing the electric circuit board sensitivity

- Switch off the control panel using the master switch.
- Hold down the button shown at the side and simultaneously turn the machine back on using the master switch.
- Now by pressing this button multiple times, you can increase or decrease the sensitivity of the electric circuit board to match the power of the tools, if the default sensitivity level is not suitable.

The sensitivity settings are: (I) - (II) - (III).

Setting (I) is the maximum sensitivity.

N.B. The default setting is (II).

- Press the ENTER button shown at the side to set or confirm the desired sensitivity level.

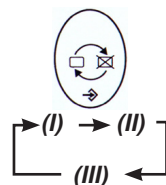

OPERATING MODES

- Ensure that there is an air supply to the compressed air inlet (a);
- Ensure that the dust collecting tank (f) is positioned correctly or reposition it.



Warning: Do not get your fingers caught between the filter unit and the edge of the pail. The machine is equipped with wheels; ensure that it does not move by locking the designated brake.

- Ensure that the attachments (pneumatic tools) have been connected to the suction inlet (z); close the inlet that is not being used;
- Ensure that the attachments (electrical tools) have been connected to the electrical outlet (u);
- At this point if the operator uses the pneumatic tools, the flow sensor (q) enables the electronic circuit board (w) to start up the suction turbine (t) with the set parameters. If electrical tools are used, connected to the electrical outlet (u), the enabling signal is sent to the board (w) by a rear sensor located in the electric panel;
- During operation, based on the programming of the circuit board (w), the shaking of the sleeve filters (h) takes place cyclically via the filter cleaning piston (d) connected to the solenoid valve (o);
- In addition to automatic operations, the shaking or cleaning of the filters can be operated manually, with the button located on the control panel (p);
- If all the pipes connected to the system and suction inlet are obstructed (z), the safety valve opens to prevent overheating of the turbine (s);
- To use only the compressed air it is possible to use the direct air intake (b).

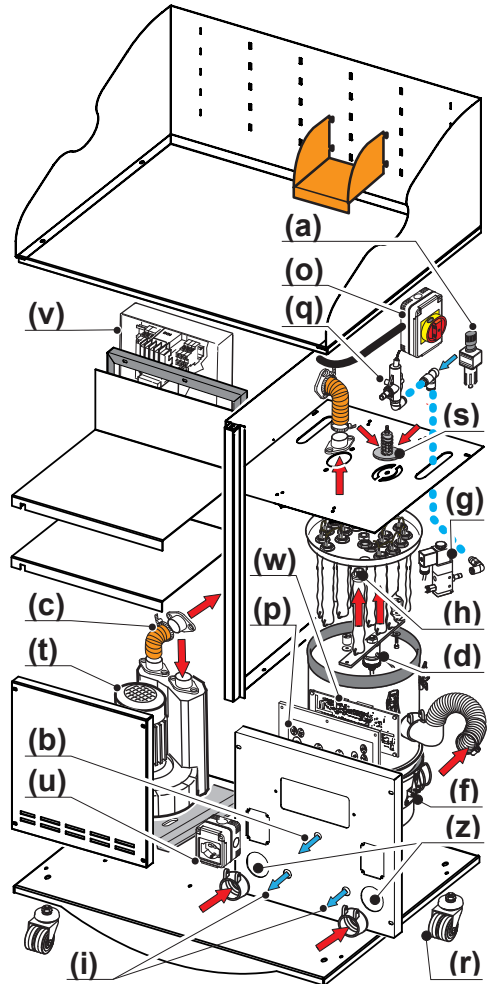







8 - Maintenance

ORDINARY MAINTENANCE

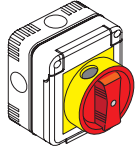

To maintain the safety and reliability of the product, repairs, maintenance or adjustments must be carried out by a qualified service center and / or qualified professional staff..

Frequency - (required time) - Type of operation Maintenance or control description	Frequency: 1 work shift (8 hours)
<p>24 hours - (10 min) - Clean the work environment Clean daily the work environment, data plates and warning signs, control panel and generally the whole machine.</p> <p><i>For example, a greasy or dirty handle can result in a dangerous situation.</i></p>	 <p>24 h</p> 
<p>24 hours - (20 min) - Check buttons and safety systems Carry out a visual examination of the buttons and safety systems daily and check their intervention</p>	 <p>24 h</p>
<p>24 hours - (5 min) - Check efficiency of main switch Check, end of the turn, the efficiency of the main switch.</p> <p><i>The efficiency of the main switch ensures safety.</i></p>	 <p>24 h</p> 
<p>1000 hours - (30 min) - Clean the electric motor fans Clean the electric motors cooling fans every six months, which are provided.</p>	 <p>1.000 h</p>

Frequency - (required time) - Type of operation

Maintenance or control description

**Frequency: 1
work shift
(8 hours)**





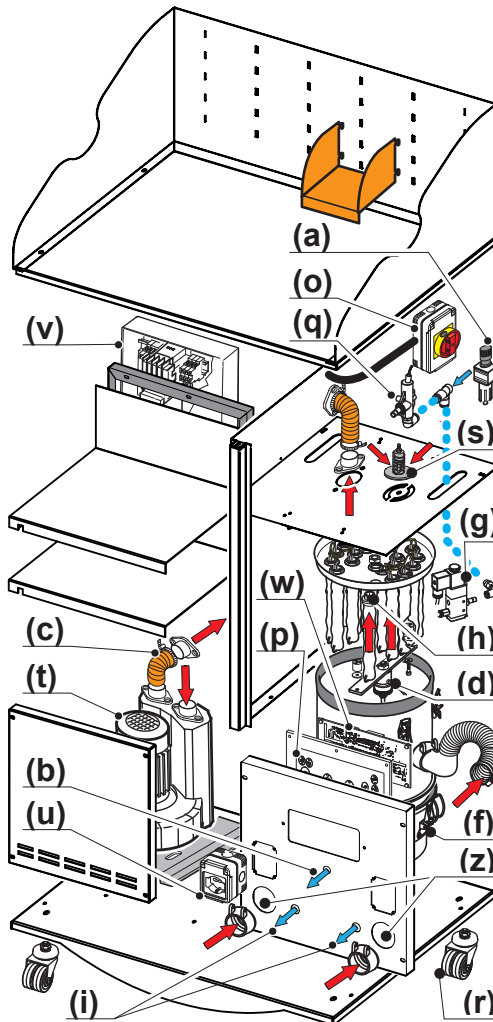

24 hours - (10 min) - Check leaks plants

Check that there are no leaks and/or spills on lubricated compressed air filter (a), from condensate discharge device and pneumatic system; also suction hoses (c) and suction mouth (z).



24 h



Frequency - (required time) - Type of operation Maintenance or control description	Frequency: 1 work shift (8 hours)
<p>1000 hours - (30 min) - Check pneumatic cylinder Check the efficiency and condition of the filter cleaning piston (d)</p>	 <p>1.000 h</p>
<p>24 hours - (10 min) - Clean the dust collecting tank Daily, or when needed, clean the dust collecting tank (f): After having emptied the dust collection tank, restore it. <i>Caution: Do not crush the fingers between the filter group and the tank edge and reposition it correctly. The machine is equipped with wheels; ensure that it does not move by locking the designated brake.</i></p>	 <p>24 h</p> 
<p>1000 hours - (60 min) - Replace the sleeves filters Every six months check the condition of sleeve filters (h). Replace the sleeve filters if there is dust inside of the machine and if the suction turbine (t) seems overloaded, noisy, or if it seems to have low suction.</p>	 <p>1.000 h</p>
<p>1000 hours - (15 min) - Check the safety valve Every six months, or more frequently in case of overheating or poor suction of the suction turbine (t), check the efficiency of the safety valve (s).</p>	 <p>1.000 h</p>
<p>1000 hours - (30 min) - Tighten the screws Every six months or when needed, tighten all the screws, including those of electrical panel components (v) (cable lugs, relay, switches, etc...).</p>	 <p>1.000 h</p>
<p>10000 hours - (2 hours) - Replace all consumable parts Every 5 years or more frequently depending on use, replace all consumable parts: sleeve filters, pipes (c), suction mouth, gaskets of dust collecting tank (f) and filters group, safety valve (s), electric and pneumatic components if needed. <i>For complete machine check contact the manufacturer</i></p>	 <p>10.000 h</p>

ROUTINE MAINTENANCE

Frequency - (required time) - Type of operation pag.
1 work shift
(8 hours)

24 hours	
24 hours - (5 min) - Check efficiency of main switch	36
24 hours - (10 min) - Check leaks plants.....	37
24 hours - (10 min) - Clean the dust collecting tank	38
24 hours - (10 min) - Clean the work environment	36
24 hours - (20 min) - Check buttons and safety systems	36
1.000 hours	
1000 hours - (15 min) - Check the safety valve.....	38
1000 hours - (30 min) - Check pneumatic cylinder.....	38
1000 hours - (30 min) - Clean the electric motor fans	36
1000 hours - (30 min) - Tighten the screws	38
1000 hours - (60 min) - Replace the sleeves filters	38
10.000 hours	
10000 hours - (2 hours) - Replace all consumable parts.....	38

STORAGE AND SCRAPPING

Machine storage and prolonged disuse

If the machine is not used immediately or is stored for long periods, stored in a closed area, well ventilated without any elements that constitute a risk of damage to components, in particular electronic parts.

Protect the machine from corrosion and store it with dessicants.



In any event, after prolonged periods of disuse, the machine must be checked and inspected by qualified professional personnel. These procedures are not described in this manual; request instructions from the manufacturer.

Machine decommissioning, scrapping or disposal

- Disconnect the electrical, pneumatic power lines etc.
- Drain all tanks and components containing harmful substances.
- Eliminate and accumulated voltage and/or residual energy.
- Dispose of the various types of component/element at specific disposal centres according to the type of material.



Users must ensure that the machine is disposed of according to standard procedures to avoid pollution, arranging for delivery to the specified collection centre for the recycling of electrical and electronic equipment.

The manufacturer declines all liability for damage to the environment or systems used for the disposal of materials: machine materials or materials intended for its use.

Table: product disposal

COMPONENT	CONSTRUCTION MATERIAL
Frame and guards	FE37 steel / Painted and treated sheet
Paint	Solvents and chemical substances
Engines.....	Steel/Cast iron/Copper
Seals.....	Rubber/Teflon/Viton/Vulkolan/Kevlar
Electrical cables.....	Copper/Rubber
Printed circuits.....	Copper/Tin/Acid/Resin
Packaging.....	Wood/Paper
Processing waste	depending on field of application
Maintenance or operating materials	Spent lubricants and oils

9 - Attachments



GENERAL CONDITIONS

The ATTACHED documentation is intended for qualified professional personnel.

The manual and attachments cannot be considered a replacement for any lack of cultural or professional knowledge of the operators, and therefore the client must ensure that these persons are able to correctly interpret all contents of these documents.



CAUTION: This document contains only the information deemed necessary for the use and routine maintenance of the machine. Before activation and use of the machine, ensure that all documentation is present as required for its operation and maintenance.

WAIVER

The client may NOT request exemption from liability, regarded as null and void in the following cases: request in breach of safety standards; negligence or serious failure to fulfil requirements; serious misconduct by an operator.

No rights of waiver from responsibility for poor interpretation or negligence with respect to instructions provided are admitted.

If, for any logical and legitimate reason, one or more operators do not wish to assume responsibility for use of the machine in safety conditions, these persons must abstain from use of the latter and contact the manufacturer for clarifications and, where possible, remedies to the problems or safety conditions found.

The manufacturer declines all requests for waiver of responsibility by the client, unless completely justified and motivated.

